

# Automatic clothesline retrieval system for domestic purposes

DAB Manthika<sup>1</sup>, EMHT Ekanayake<sup>2</sup> and KN Perera<sup>3#</sup>

<sup>1,2,3</sup> Faculty of Engineering, General Sir John Kotelawala Defence University, Sri Lanka

# <37-eng-0079@kdu.ac.lk >

**Abstract** - This study addresses a common issue faced by households, focusing on the troublesome task of drying clothes. Unpredictable weather conditions often result in clothes getting soaked and drenched in rainwater, causing unpleasant odors. Working families, with their busy schedules, resort to indoor drying as a solution, unaware that it can lead to unhygienic conditions and allergies. Additionally, indoor dryers are costly, and further outdoor drying requires constant monitoring to check if clothes are dry, adding to the already overwhelming workload. To address these challenges, this project proposes an innovative solution, an Automatic Clothesline Retrieval System that effectively shelters clothes during rain and provides convenient drying options. The system incorporates inputs such as rain presence, light intensity, cloth drying state, and user feedback, which are processed by an Arduino microcontroller. In response, a stepper motor, controlled by a driver circuit, is activated, and the user is notified via a GSM module about rain events and the drying progress. The stepper motor's rotational motion drives a gear connected to a railing, enabling smooth movement of the clothesline slots between sheltered and outdoor positions. By introducing this system, households can overcome the challenges of unpredictable weather and manual monitoring, ensuring efficient and convenient clothes drying.

**Keywords**— Automatic, GSM, LDR, Microcontroller, Rain sensor, Stepper motor

## I. INTRODUCTION

In today's fast-paced world, individuals, including students and working adults, face the challenge of managing multiple responsibilities simultaneously. Among various household tasks, drying laundry on a clothesline can be particularly troublesome. With busy schedules and unpredictable weather, people often struggle to attend to their clothes when unexpected rain occurs, resulting in damp and soaked garments. While hanging clothes outside in the sun is an eco-friendly method, modern innovations such as retractable cloth racks have made the process more efficient. However, the fear of sudden rain showers leads many households to opt for indoor drying, which can result in unhygienic conditions

and trigger allergies. Laundry dryers offer an alternative but come with their own drawbacks of high cost, energy consumption, and carbon emissions. Additionally, managing daily routines becomes challenging as individuals need to repeatedly check if clothes are dry, and prolonged sunlight exposure can cause fabric damage (S *et al.*, 2017). To address these challenges, it is crucial to develop an automatic clothesline retrieval system to protect clothes by moving them indoors during rainy conditions. This project aims to introduce an automated solution capable of sensing rain, light intensity, and the moisture level of clothes, thereby notifying users and facilitating efficient retrieval of the clothesline.

By implementing this innovative approach, individuals can effectively manage their laundry drying process, minimizing the risks of dampness, allergies, and fading fabrics. The development of an automatic clothesline retrieval system will significantly improve the convenience and effectiveness of drying clothes, particularly for busy working households.

The following sections of this study will delve into the details of the system's design, functionality, and implementation, along with the outcome and potential implications of this innovative solution.

## II. LITERATURE REVIEW

The paper “Automatic Clothesline Retrieval Prototype with Humidity Alert System to Aid Clothesline Drawbacks for Reducing Laundry Worries” is (Nur Aisyah Abdul Hei *et al.*, 2021) an innovative solution to address the challenge faced by individuals who struggle to retrieve their clothesline in changing weather conditions. This research project focuses on the development of an Internet of Things (IoT) based prototype system equipped with a humidity sensor and a dedicated application. The methodology employed in this study follows the prototype model approach. Key hardware components utilized include the DHT22 Humidity Sensor and Micro Servo, with the system being powered by a laptop. The results obtained from the project demonstrate the successful functionality of the prototype, as it effectively responds to changes in humidity and light readings in its surrounding environment. An extensive survey conducted on

the project revealed that all respondents expressed interest in the ACR prototype system. This research significantly contributes to the realm of automating household tasks, relieving the concerns of busy individuals and enhancing their overall user experience.

The study “Automatic Retractable Cloth Drying System” by (Ishak *et al.*, 2020) is a development of an automatic cloth drying system that can retrieve and retract clothes based on weather conditions and addresses the growing need for convenience in our daily routines. This project utilizes an Arduino UNO microcontroller along with two sensors, a rain sensor and an LDR (Light Dependent Resistor), to detect rainfall and sunlight respectively. The system incorporates a power window motor to convert electrical power into mechanical power, enabling the movement of a retractable cloth drying system capable of supporting up to 5 kg of wet clothes. The sensitivity of each sensor can be adjusted to set the system's operational conditions. The project also includes the use of a retractable clothesline with three bars, providing an optimal solution for individuals residing in space-limited environments such as flats. The final product comprises a commercial wall-mounted retractable drying rack cloth hanger, with the power window motor synchronized to retract and extend the cloth rack based on the pre-defined conditions. The system is designed to accommodate approximately ten to fifteen clothes at a time, depending on their size. This automatic retractable cloth drying system effectively addresses the laundry challenges faced by busy individuals and working couples, offering an efficient solution that adapts to changing weather conditions, thus eliminating the need for a dedicated laundry day.

The paper “Design and performance analysis of smart roof clothesline system based on Microcontroller by smartphone application” (Putri, Perdana and Bisono, 2018). This study created a smart clothing roofing system that users can control and monitor using a smartphone application. The rain sensor, humidity and temperature sensors (DHT22), and light sensor (LDR) are all used in this system. The NRF24L01 transceiver module, the Arduino Uno microcontroller, and the Raspberry Pi serve as the gateway to the VPS. A smart roof clothesline system is a roofing system that can open and close the roof in rainy conditions. A smartphone can be used to monitor and control the roof. This system is based on the smart home concept, and it requires certain hardware and software to be deployed. Sensors (rain sensor, temperature, and humidity sensor, light sensor), NRF24L01, servo motor, Arduino, and Raspberry PI are combined to build a smart roof clothesline system. The monitoring and controlling processes are both present in this system. The monitoring phase involves delivering sensor data and roof status data to the user, whereas the controlling process involves the user issuing commands to close or open the roof via a smartphone. The monitoring phase involves delivering sensor and roof status

data to the user, whereas the controlling process involves the user issuing commands to close or open the roof via a smartphone. The Arduino will also serve as a roof drive, while the NRF24L01 will serve as a wireless communication module. On a local server, the Raspberry Pi will be linked to the NRF24L01, which is linked to Arduino. The internet server is utilized for the system that was created to allow users to connect using their Android smartphones. As a result, consumers may monitor and control their devices using the Android app (Putri, Perdana and Bisono, 2018).

The paper “Design and Experimental Study on Automatic Cloth Retrieval and Drying System” (S *et al.*, 2017) proposes a methodology to automatically retrieve clothes when it is sunny and retrieve in clothes when it is raining using microcontroller PIC 16F877 which installs all programs which give instructions to conduct this system properly. This system requires a DC motor to transform electrical power into mechanical power in order to retrieve and return all of the clothing. Temperature sensors used in this research can more correctly assess temperature and day conditions, such as whether it is sunny or rainy. To detect light, LDR (Light Dependent Resistor) sensors are utilized. Rain detectors are used to detect when it begins to rain outdoors by detecting rainwater from the rod's moisture impedance sensor. The garments' drying time will be controlled using a rotary knob switch, and it will automatically retrieve the clothing using a DC motor when the drying time is up. This project will use an LCD (Liquid Crystal Display) or an indicator light such as an LED (Light Emitting Diode) to display the current day's weather, temperature, and dry-timer. The DC motor is powered by either an AC power source that is converted to DC using a diode circuit or a battery that is included with the project kit. Because the battery is only accessible in 12V, the system uses an electrical step-up transformer circuit board to increase the voltage to a higher value that is closer to the working voltage of the provided motor. Another benefit of this solution is that the given battery is constantly charged by solar panels mounted above the roof.

The paper titled "Automatic Cloth Retriever System" (Lumitha *et. al.*, 2016) presents a novel system designed to autonomously retrieve clothes based on weather conditions. The system employs various components, including a PIC microcontroller, temperature sensor, impedance sensor, rain detector sensor, light-dependent sensor, DC motor, and GSM module. The project utilizes the Microcontroller PIC 16F877 to install a comprehensive program that enables the system to accurately respond to different weather scenarios by automatically retrieving clothes during sunny days and retracting them during rainy days.

The implementation of this project involved developing a circuit using a Light Dependent Resistor to detect sunny conditions and a rain detector circuit to identify rainy days.

The controller was programmed to effectively control the motor, facilitating the retrieval of clothes during sunny days and their retraction during rainy days. Additionally, the system incorporates a dry-time mechanism that calculates the duration required for clothes to dry. Once the designated dry time has elapsed, the system automatically retrieves the clothes. Users have the flexibility to set the dry time, selecting from options such as 3 hours, 4 hours, or 5 hours. The project's user interface displays essential information including the current day condition (sunny, cloudy, or rainy), temperature, and the dry time set by the user. Moreover, the interface showcases the user-defined dry-timer. The system retrieves clothes once the drying process is completed, during rainy days, when there are no sunny conditions, and when the temperature falls below 25°C. The motor rotates 90 degrees for both the retrieval and retraction actions.

The paper "Development of Intelligent Clothesline System" (Chun *et al.*, 2019) presents a comprehensive project that focuses on the creation of an automated clothesline system capable of responding to environmental changes. The system incorporates various components, including a microcontroller (Arduino UNO R3), light-dependent resistor (LDR) sensor, rain sensor, and DC motor, to enable the automatic operation of the clothesline system based on the surrounding conditions. Following thorough calculations and range setting, the threshold values for the LDR and rain sensor modules were determined as 20 and 657, respectively, after digital conversion. These threshold values facilitated the discrimination of voltage readings, allowing the system to determine the brightness of the surroundings and the presence of raindrops. A crucial component in this project is the limit switch, which ensures that the motor ceases its operation once the clothes have reached a specific limit, either when pushed or pulled. To facilitate the directional control of the DC motor, a motor driver, specifically the L293D, was employed. Its selection was based on its wide supply voltage range of 4.5V to 36V, enabling optimal operation within the system. In this project, when the sensors detect either rain or low light intensity, the clothes are automatically covered. The integration of the microcontroller, sensors, motor, and motor driver ensures the reliable and efficient operation of the intelligent clothesline system.

### III. SCOPE / LIMITATIONS

The scope of this project is to develop an automatic clothesline retrieval system, that can shelter the clothes in the instance of rain, night, complete drying time, and user feedback.

The system has certain limitations. The Dryer moisture sensor relies on predefined values to determine the drying status of the clothesline. While this provides a basic indication of when the clothes are completely dried, it may not account for variations in fabric types, weather conditions,

or individual preferences since the sensor is clipped to only one cloth based on fabrication tests and does not contact the whole area of the cloth. Therefore, the system's assessment of the drying status may not always align perfectly with user expectations. Moreover, the model is a custom tailor-made design. The design can be modified according to the user's choice, depending on the house's measurements. Hence the model is installed beforehand and is not portable.

## IV. METHODOLOGY

### A. Framework and methodology of the study design

The framework utilizes an array of components and sensors to ensure optimal management of the clothesline's position, protecting the clothes from rain and facilitating efficient drying.

The hardware implementation of the system incorporates the concept of linear guide rails to control the movement of the clothesline. A stepper motor is utilized, which is connected to a linear guide rail using a coupling mechanism. The lines with hooks, on which the clothes are hung, are mounted at either side of the railing.

The purpose of the stepper motor is to rotate the guide rail thereby causing the entire clothesline system to slide forward or backward. When the motor rotates in one direction, the clothesline moves towards the desired position, either outdoors or to the sheltered area. The coupling ensures a secure connection between the motor and the railing, enabling smooth and synchronized movement.

To ensure accurate positioning and prevent overextension or misalignment, a limit switch is incorporated. This switch is strategically placed at the limit of the range of motion. When the clothesline reaches either end of the rail, the limit switch detects this position and signals the control system to stop the motor. This prevents any further movement, ensuring that the clothesline remains within the intended range and operates safely and effectively.

The functionality of the system is shown in the flowchart in figure 1. It begins by offering the user the ability to take full control using a manual switch. This switch state is checked, and if it is set to 1, the clothesline is instructed to be sent to the shelter as per the user's command. In addition, LDR bulbs are activated, enabling the system to determine the light intensity level. Based on this information, during nighttime (when the light intensity is low, represented by 1), the clothesline is automatically sent to the shelter. Conversely, during the day (when the light intensity is high, represented by 0), the clothesline remains outdoors.

The system incorporates a rain sensor that detects the presence of raindrops. If the rain sensor surpasses the

specified limit, indicating rainfall, the clothesline is immediately sent to the shelter. To inform the user of this action, the system employs a SIM800L GSM module, which sends an alert message stating, "Raining, clothesline is sent to a shelter."

Furthermore, the system considers the wetness of the clothes on the line. Based on predefined values, the cloth that requires the longest drying time is monitored. Once this cloth is completely dried, the system sends a notification to the user, stating, "Whole clothesline is dried, sent to the shelter." Consequently, the clothesline is moved to the sheltered position. The design framework effectively integrates the various components to provide comprehensive control and monitoring of the clothesline. By incorporating user input, light intensity sensing, rain detection, and cloth wetness monitoring, the system ensures optimal management of the clothesline's position, safeguarding the clothes from rain and facilitating efficient drying.

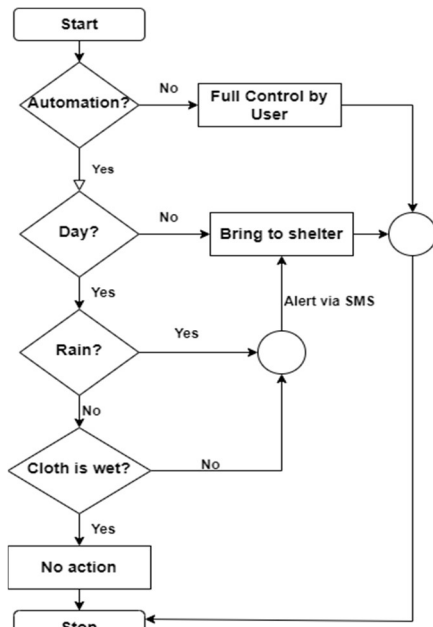

Figure 1. The flowchart of the design

## V. PROTOTYPE DESIGN AND SYSTEM ARCHITECTURE

### A. Circuit and Software Analysis

1) *Rain sensor Module and Test:* A rain sensor is a sensor that detects the presence of rain by measuring the amount of water that falls on the sensor panel. The rain sensor works on the idea that when it rains on the sensor panel, the rainwater electrolyzes it. It occurs as a result of rainwater being included in the electrolyte liquid, where it can conduct electrical current, although very little, and this process will

activate the relay in the sensor module (Putri, Perdana and Bisono, 2018).

Depending on the volume of water the displayed voltage was analyzed on the serial monitor. Different volumes of water were used as the manipulative variable. Read analog signal code was uploaded to the Arduino board and the results were obtained. The minimum amount of activation was enabled to be 0.1 ml of water with a voltage level of 2.3V as shown in figure 2.

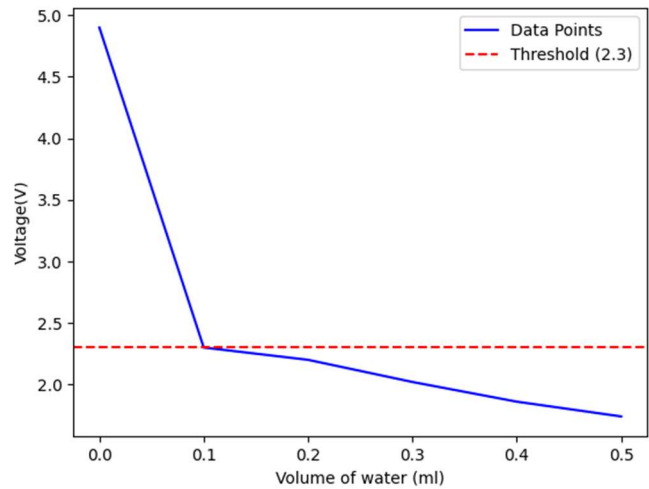

Figure 2. Voltage vs. Volume of water variation in Rain Sensor Test

2) *LDR Module and Test:* LDR (Light Dependent Resistor) is a type of resistor that is widely used as a light detector or to monitor light conversion. Light Dependent Resistors are made up of a semiconductor disk with two electrodes on the surface. However, because of the slow reaction to light, LDR

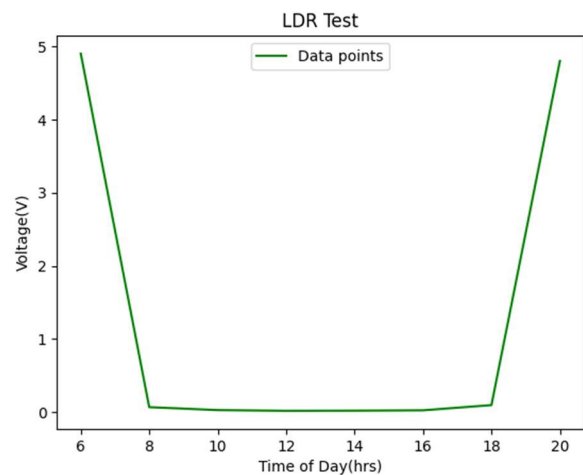

Figure 3. The graph of Voltage vs. time of day

is not effective in situations where the intensity of light

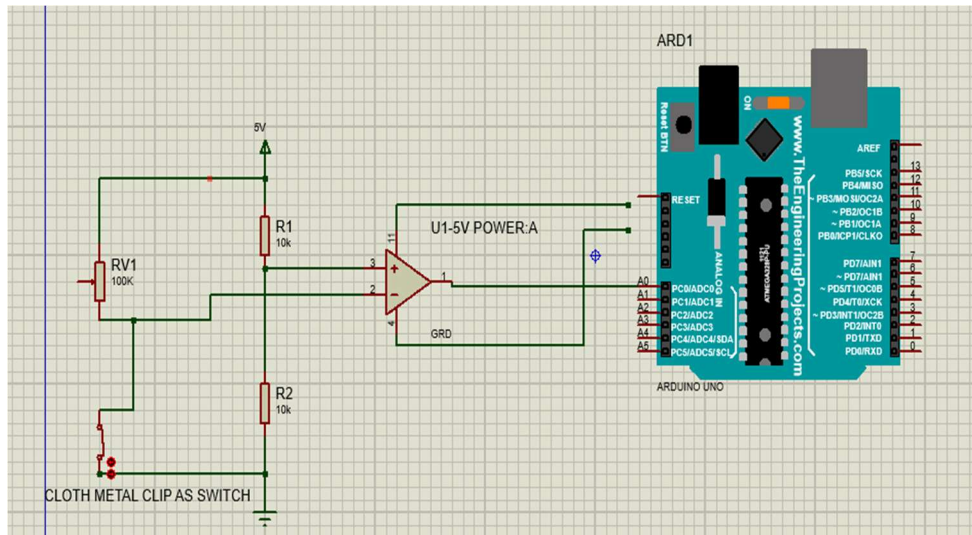

Figure 4. The circuit diagram of dryer moisture sensor

changes dramatically. If the brightness of the light changes, the resistance value of this sensor changes (Putri, Perdana and Bisono, 2018).

Depending on the light intensity of the environment. The analog voltage across the LDR was expected to change once the light intensity changed. It is observed that when the surrounding has low light intensity, logic level 1 is displayed, while logic level 0 is when high light intensity. The sensitivity of LDR is increased by rotating the knob of the comparator for accurate results. Figure 3 depicts the voltage curve at the LDR sensor with respect to the time intervals per day.

*3)Dryer Moisture sensor and Test:* This sensor was made using an LM324 Op-amp, preset variable resistor, and 1K resistors. Crocodile clips with a covering were used as the clip which was attached to the cloth which takes the highest amount of time to dry. A 5V power was given to the setup. The voltage level was in the range of 2.5-4.5V when detecting the wetness level. The input pin is set to Analog pin 1 of the microcontroller(A1).

A wet and dry cloth was clipped to two crocodile clips and the voltage level on the serial monitor was observed. A maximum of 5V was given as power to the sensor, and the preset variable resistor was adjusted to give a more of a high impedance value, so as to limit the current flowing through the Arduino board. A 2.5V was observed when the current through the sensor is 0, and that was used as the threshold value to trigger the sensor. The circuit diagram for the dryer moisture sensor is shown below in Figure 4. The current through the switch depicts the water conduction. The

difference through the amplifier is given as the output to the microcontroller.

### B. Hardware Analysis

*1). Prototype Design:* The mechanical aspect of the project encompasses tasks such as hardware sorting, gathering, and assembly. In order to construct the desired design, metal bars, and tubes are utilized. The system incorporates railings to facilitate the movement of the clothesline, employing the "Linear Rail Guide" concept. To enable rotation of the railings, a Stepper Motor is employed. The motor is connected to the railing using a Flexible Coupling. Furthermore, a designed enclosure is incorporated to provide protection and containment. The length of the rail in which the clothesline extends is 30cm. The width of the clothesline of the prototype is 30cm. The prototype can be scaled into an actual implementation in the ratio of 1:5. The SOLIDWORKS Premium 2020 software is utilized to create precise sketches and determine the appropriate dimensions for the parts assembly as shown in figure 5 (side view) and figure 6 (Top view).

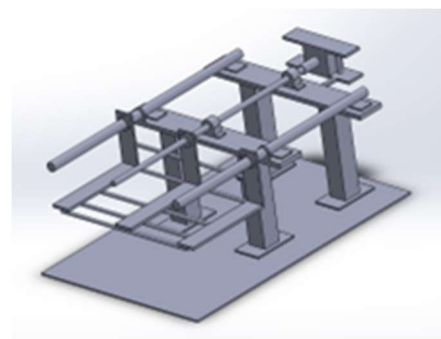

Figure 5. Side View

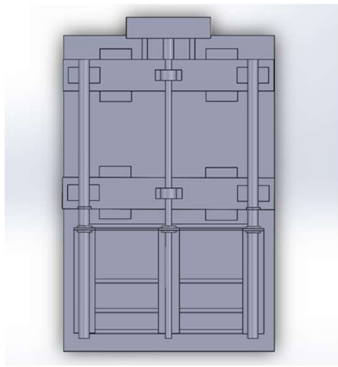

Figure 6. Top View

2). *Material Selection:* During the material selection process for the product, several crucial factors were taken into consideration. These factors included lightweight properties, resistance to rust, ability to withstand splashes, durability, and the capacity to support a specific weight. After careful evaluation, it was determined that Aluminum met all the requirements outlined above. Hence, Aluminum was chosen as the ideal material for the product, as it successfully fulfills all the desired criteria.

## VI. RESULTS

The implemented hardware as shown in Figure 8 successfully incorporates a threshold value-based approach for determining the appropriate action of the clothesline system. By comparing the sensed value against the threshold, the system effectively determines whether the clothesline should be moved out or brought in. Additionally, the system offers remote monitoring functionality, enabling users to receive real-time updates on the status of the system. This is accomplished through the use of a GSM module with a SIM card, allowing the system to send informative messages to the user as shown in Figure 7 of a snapshot of the message.

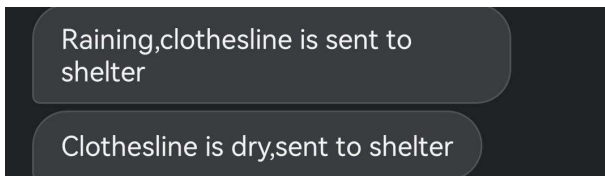

Figure 7. The snapshot of the message via GSM

## VII. CONCLUSION

The successful implementation of the scaled-down version of the design of the Automatic Clothesline Retrieval system demonstrates its practicality in addressing laundry-related challenges and offering numerous benefits in the context of our fast-paced modern lifestyle.



Figure 8. Hardware implementation of prototype

This innovative system significantly enhances the efficiency of daily routines, as it minimizes the time required to retrieve clothes from the clothesline compared to manual methods. Furthermore, the inclusion of an intuitive alert system in this project provides users with convenient updates regarding the status of their clothesline and laundry, further streamlining their experience.

## VIII. RECOMMENDATION

In addition to its existing capabilities, the system can be enhanced through various modifications to provide additional functionalities. A humidity sensor can be used as the accuracy measurement of the system will be further increased. One potential modification is to incorporate a weight measurement feature that alerts users when the weight limit of the clothesline is exceeded. This would help prevent overloading and potential damage to the clothesline. Another modification could involve scaling up the system to accommodate a common clothesline shared by multiple users. In such a scenario, the system could be adapted to detect the wet or dry state of individual items of clothing, enabling users to easily identify and retrieve their own dry clothes. Furthermore, the system could be extended to include a folding mechanism by integrating a conveyor belt and a robotic arm. This advanced feature would automate the process of folding the laundry once the entire clothesline is dry, saving users time and effort. These proposed modifications demonstrate the potential for further development and expansion of the system, offering enhanced functionality and convenience for users in managing their laundry tasks.

## REFERENCES

- Chun, L., Talib, N., Jaafar, H., Shariffudin, N. and Ramli, N., (2019), November. Development of Intelligent Clothesline Sytem. *In Proceedings of The 2nd International Conference On Advance And Scientific Innovation, ICASI 2019*, 18 July, Banda Aceh, Indonesia.
- Ishak, N.N., Shah, N.S.M., Zainal, M.S., Mohamad, M. and Rahman, M.A., (2020). Automatic Retractable Cloth Drying



System. Progress in Engineering Application and Technology, 1(1), pp.198-205.

Lumitha Seema Cutinhal , Manasa k2 Venkatesh Pai3, S.B. 4 (2016) ‘Automatic Cloth Retriever System’, *International Research Journal of Engineering and Technology (IRJET)*, 03(March), pp. 243–246.

Berahim, M., Hei, S.N.A.A., Nazri, E.N. and Rafik, N.F.M., 2021. Automatic Clothesline Retrieval Prototype with Humidity Alert System to Aid Clothesline Drawbacks for Reducing Laundry Worries. *Multidisciplinary Applied Research and Innovation*, 2(1), pp.401-410.

Putri, D.R., Perdana, D.P. and Bisono, Y.G., 2017. Design and performance analysis of smart roof clothesline system based on microcontroller by smartphone application. *TEKTRIKA-Jurnal Penelitian dan Pengembangan Telekomunikasi, Kendali, Komputer, Elektrik, dan Elektronika*, 2(1).

Kumar, S., Selvaganapathy, M., & Kumaresan, G. (2017). Design and experimental study on automatic cloth retrieval and drying system. *Int. J. Adv. Res. Ideas Innov. Technol*, 3(2), 49-57.

#### ACKNOWLEDGMENT

We would like to extend our sincere appreciation to Prof. Rohan Lucas for his invaluable oversight of this research paper.

#### AUTHOR BIOGRAPHIES



Bimali Manthika is an Electrical and Electronic engineering undergraduate in the Department of Electrical, Electronic, and Telecommunication at General Sir John Kotelawala Defence University.



Himasha Ekanayake is an Electrical and Electronic engineering undergraduate in the Department of Electrical, Electronic and Telecommunication at General Sir John Kotelawala Defence University.



Kevini Perera is an Electronic and Telecommunication engineering undergraduate in the Department of Electrical, Electronic, and Telecommunication at General Sir John Kotelawala Defence University.