

# Gesture Controlled Glove for a Military Team's Communication

KT Sehan<sup>1#</sup>, RM Chanaka Pradeep Ranasinghe<sup>2,3</sup>, MRRA Bandara<sup>3</sup>

<sup>1,2,3</sup> Department of Electrical, Electronic and Telecommunication Engineering  
Faculty of Engineering

General Sir John Kotelawala Defence University

# <ktharushasehan@gmail.com>

**Abstract**— This paper presents a handheld Set that works with an Arduino based technology for military team's silence communication. The product basically contains the Arduino board, Transceiver (Bluetooth Module Class 1 with Onboard Antenna – LM400), flex sensors, handsfree and gloves. Effective and efficient communication through silence is essential for the success of special military operations and the protection of the troops. Soldiers must infiltrate hostile territory in small teams, such as four- or eight-man teams, for a variety of operations, including reconnaissance (LRRP; Long Range Reconnaissance Patrols), sniper operations, hostage rescue, and small team ambush missions and Fight in Build-up Areas (FIBUA). Since it directly affects the success of the mission and the lives of the men engaged, maintaining silence becomes crucial in these circumstances. The proposed glove leverages advanced sensor technology and gesture recognition algorithms to enable intuitive and hands-free communication for military personnel. By capturing and interpreting hand movements and gestures, the glove translates them into predefined commands allowing for seamless and discreet communication without the need for verbal cues or traditional devices and traditional methods such as Famous military hand signals cannot be used effectively in dense jungles where soldiers may not be visible to one another. The system integrates wireless communication modules to transmit the interpreted signals to team members, ensuring real-time, secure, and reliable communication and to avoid misleads

**Keywords**— Flex sensors, silent communication, gestures

## I. INTRODUCTION

In military operations, effective and secure communication plays a critical role in ensuring mission success. In certain situations, maintaining silence is of utmost importance to avoid detection or compromise. As examples following scenarios can be considered: the capacity to remain silent is essential for clandestinely acquiring intelligence and avoiding adversary discovery during reconnaissance missions. Similar to this, maintaining silence during sniper operations helps snipers keep their covert locations and ensures the element of

surprise. The likelihood of a successful operation is increased in hostage rescue scenarios where excellent communication through silence enables the rescuing team to coordinate their actions without alerting the captors. Silence also enables the team to move covertly and carry out their tactical goals without endangering their position during small team ambush missions. The importance of effective quiet communication cannot be emphasized given the nature of these operations, which involve soldiers working in tiny groups deep within enemy territory. For the mission to be safe and successful as well as to retain stealth, it is essential to be able to communicate orders, directives, and situational information without using verbal cues. Therefore, it is crucial to research efficient methods and strategies for silent communication in these specialized military operations.

Military operations have found use in hand gesture gloves made for silent communication, which give soldiers a way to communicate orders without using words. Military applications that use hand gesture gloves for silent communication make use of cutting-edge sensor technology and gesture recognition algorithms. These gloves come with sensors, primarily flex sensors, which record the precise movements and hand locations of the user. The information is then analyzed using sophisticated algorithms that can identify particular gestures connected to pre-defined commands. In military settings, silent communication gloves have various benefits. By doing away with the necessity for directives that could be heard, they enable soldiers to remain covert. Without jeopardizing operational security, tactical instructions like movement signals, target designations, or squad formations can be communicated by silent hand gestures. Furthermore, hand gesture gloves make it possible to communicate in noisy settings where verbal communication could be challenging or impossible. Soldiers are able to communicate vital information and secretly plan activities to ensure successful operations under trying circumstances. The potential influence of hand gesture gloves for quiet communication in military applications is substantial, notwithstanding their early phases of research. In order to meet the special requirements of military operations, additional research and development in this field offer promise for improving the precision, dependability, and adaptability of these gloves. In conclusion, hand gesture gloves made for silent

communication provide a useful way for military personnel to communicate orders and information covertly, boosting situational awareness and operational safety. As technology advances, these gloves have the potential to become a vital component of modern military communication systems, providing soldiers with a silent and efficient means of coordination and maintaining the tactical edge in complex and sensitive environments.

## II. LITERATURE REVIEW

The flex sensors are versatile devices which are able to detect and measure as well the degree of bending or flexing. (Pavan Telluri, 2020) Hand gesture are used in sign language and are a way of communication for deaf and mute people. They are aiming to provide an electronic method for hand gesture recognition which is cost effective, this system makes use of flex sensors, on-board gyroscopes and accelerometer.

(N. Muthmainnah Mohd Noor, 2022) The flex sensor's glove is able to control a basic racing game in the PC smoothly as well as the traditional methods such as joystick and keyboard. This project was successfully developed the hand gestures based on the flex sensors for the three fingers: - middle, thumb, and index. It also able to control the movement of the three movement of racing car (forward, left, and right).

(Nimi. W. S, 2023) In healthcare network breach of privacy issues may arise from the implementation of vision cameras for continuous patient monitoring. To overcome this, a method for tracking the position of patients is proposed using a tiny sensor placed on a patient clothing. A flexible sensor based on polyvinylidene fluoride with flexible piezoelectric material is used. The flexible sensors are placed onto clothing of the patient that is close to the backbone of the patient.

In military operations, effective communication is essential, and radio sets have traditionally been the main form of communication for military personnel. Technology developments have, nevertheless, created new opportunities for investigating non-conventional forms of communication. This overview of the literature explores the creation and conceivable benefits of a gesture-controlled glove for military team communication, offering a fresh strategy different from currently available radio sets.

Hand-Held Radio Set, PRM-4515 Cougar. (Cryptomuseum,2023) illustrates that, the PRM-4515 Cougar Hand-Held Radio Set is a tough portable military radio that is frequently used by Special Forces and in covert police operations and works under UHF High Band frequency range. It was designed by Racal Tacticom Ltd in

the late 1980s. It provides secure communication in a variety of applications, including covert operations, surveillance, and VIP protection, and comes with optional 16 kbit/sec digital voice encryption. The PRM-4515 still uses voice instructions to deliver messages, though.

RF-7800V-HH Handheld VHF Tactical Radio. (13harris,2023) indicates, the FALCON III®: With high speeds and long transmission ranges, the FALCON III RF-7800V-HH Handheld VHF Tactical Radio enables simultaneous speech and data communication. Through the use of its Quicklook ECCM waveform package and Free Channel Search technology, it provides safe mission communications in noisy settings. It does, however, rely on voice commands, just like conventional radio sets.

(motorolasolutions,2023) explains that, the SRX 2200 Enhanced Combat Radio is a tough two-way portable radio created to provide secure communications in difficult military conditions. It combines integrated Intra-Squad Radios (IISR) with a sturdy combat radio architecture and offers compatibility for a number of frequency bands. However, uses voice commands, just like conventional radios, to deliver messages.

Military teams can communicate silently and securely by using hand and finger motions while wearing a gesture-controlled glove proposed by the research paper. This increases operational effectiveness and lowers the chance of compromise the secret missions of the friendly forces.

## III. METHODOLOGY

### a. System Block Diagram and Operation

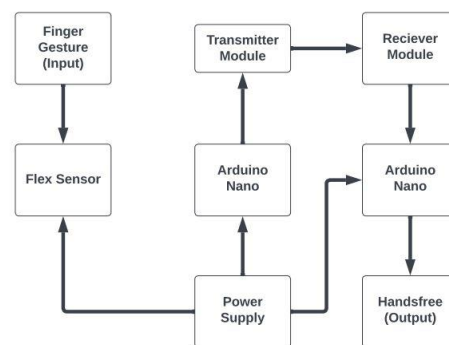

Fig 1: System Block Diagram

As illustrated at Fig.1 and as shown in fig. 3 First, while using hand movements, the bending angles of the flex sensors are measured. The programming is then done on the Arduino Nano board, with commands being assigned for each bending angle. It is possible to implement the commands using certain Arduino libraries. The orders are then modified in response to the bending angles recorded by the flex sensors.

A push button is used to guarantee prompt delivery of the necessary signal to the Arduino board. The number of commands can be expanded in line with the addition of more flex sensors. Each hand's finger has a flex sensor attached. A 9V alkaline battery powers the Arduino board with around 550 mAh of energy. The hands-free gadget and the flex sensors are powered by the Arduino board, which is tucked away inside each glove. Take the instruction "bravo bravo don't rush over" for example, which is associated with a 45-degree bend in the first finger.

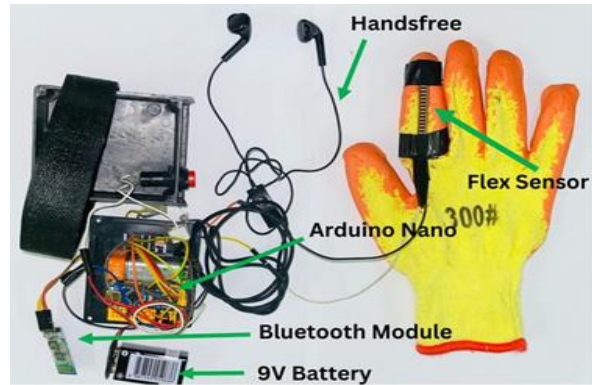

Fig 3: System Implementation of the project

As a result, the handsfree, which is attached to the soldier, communicates the voice output "bravo bravo don't rush over" to the receiver when the finger is bent to a 45-degree angle. Within a 100-meter range, this wireless communication can broadcast without any distortion.

Only one flex sensor is used in this research project. However, the quantity of flex sensors can be chosen according to the nature of the assign mission. As an illustration, the receiver end can produce the following speech commands if five flex sensors are used on each finger of the gloves as indicated at Table 1.

Finger (Flex Sensor)	Voice command generated at receivers Handheld set
Flex Sensor 1	"bravo bravo don't rush over"
Flex Sensor 2	"Execute the target"
Flex Sensor 3	" withdraw soon"
Flex Sensor 4	"Evacuate the location"
Flex Sensor 5	"Fire and manure"

Table 1: Example voice command for the glove

b. Circuit design is indicated as fig 2 and System Implementation of the project is as shown in below fig 3.

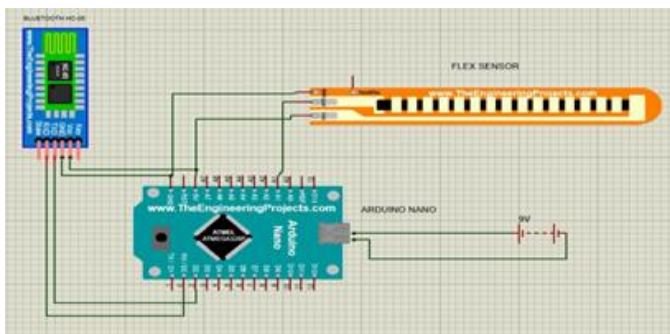

Fig 2: Circuit design

c. Component description

1. Transceiver (Bluetooth Module Onboard Antenna – LM400) : Class 1



Fig 4: Bluetooth Module Onboard Antenna – LM400

Bluetooth Module Onboard Antenna – LM400 (Fig.4) is designed to replace cable connections and uses serial communication to communicate with the electronics. Usually, it is used to connect small devices like mobile phones using a short-range wireless connection to exchange data.

- Serial Bluetooth module for Arduino and other microcontrollers
- Operating frequency : 2.45GHz frequency band
- Module type : Programmable
- Profiles : SPP
- Audio interfaces : PCM
- Antenna : IC antenna
- Weight : 4.91g +/- 0.25 tolerance
- TX output power : 18 dBm (Maximum)
- RX sensitivity : -88dBm (Typical)

2. Flex Sensor



Fig 5: Flex sensor 2.2 inches

A simple flex sensor 2.2" in length (Fig 5). As the sensor is flexed, the resistance across the sensor increases. The flex sensor has an angular sensitivity from 0 to 180 degrees considered to the finger bending. We can add up to 3 angles for one flex sensor according to our purpose Patented technology by Spectra Symbol - they claim these sensors were used in the original Nintendo Power Glove.

Applications:

- Angle Displacement Measurement
- Bends and Flexes physically with motion device
- Possible Uses
- Simple Construction
- Low Profile
- Physical Therapy
- Musical Instruments
- Computer Peripherals
- Medical Devices
- Gaming (Virtual Motion)
- Robotics

### 3. Arduino Nano



Fig 6: Arduino Nano Module

The Arduino Nano Module (Fig.6) is a small, complete, and breadboard-friendly board based on the ATmega328 (Arduino Nano 3.x). It has more or less the same functionality of the Arduino Duemilanove, but in a different package. It lacks only a DC power jack, and works with a Mini-B USB cable instead of a standard one.

- Microcontroller : ATmega328
- Architecture : AVR
- Operating Voltage: 5 V
- Flash Memory : 32 KB of which 2 KB used by bootloader
- SRAM : 2 KB
- Clock Speed : 16 MHz
- Analog IN Pins : 8
- EEPROM : 1 KB
- DC Current per I/O Pins: 40 mA (I/O Pins)
- Input Voltage : 7-12V
- Digital I/O Pins : 22 (6 of which are PWM)
- PWM Output : 6
- Power Consumption: 19 mA

## IV. Results and Discussions

The finalized product of the wearable Handheld set is as indicated at below figure:



Fig 7: Finalized product

The product has been tested in three different outdoor environments namely scenario 1: Dense Jungle (Lat: 7.1559, Lon : 79.9447), scenario 2 : Urban environment (Lat: 6.8202, Lon: 79.8920), scenario 3: Open environment (Lat:6.8172, Lon:79.8882) in order to get into military environment and the readings (Received power levels) were taken (using communication Analyzer) by increasing the distance from 10 meters by an increment of 10m of sender and receiver up to 100m. Test results are tabulated in table 2. Further, a line graph (graph 1) is drawn using the test results.

In scenario 1: up to 50 meters range, acceptable power levels were received with clear voice outputs and power level were not detected after range of 50 meters and no voice output were received. In scenario 2: up to 60 meters range, acceptable power levels were received with clear voice outputs. power level was not detected after range of 60 meters and no voice output were received. In scenario 3: up to 70 meters range, acceptable power levels were received with clear voice outputs and power level were not detected after range of 70 meters and no voice output were received.

Distance (meters)	Scenario 1 (Dense Jungle) : Received signal level(dBm)	Scenario 2 (Urban environment (Buildup area)) : Received signal level(dBm)	Scenario 3 (Open environment (Buildup area)) : Received signal level(dBm)
0-10	-10	7.5	10.4
10-20	-22	-15	2.7
20-30	-45	-52	-12.2
30-40	-50.5	-20	-23
40-50	-61	-40	-31.5
50-60	Not detected	-58	-46.9
60-70	Not detected	Not detected	-60
70-80	Not detected	Not detected	Not detected
80-90	Not detected	Not detected	Not detected
90-100	Not detected	Not detected	Not detected

Table 2: Field test results

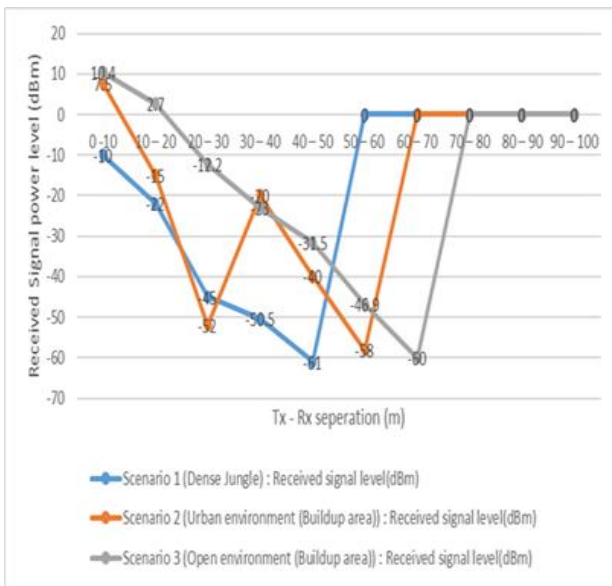

Fig 8: Received signal Power Vs Range

## V. CONCLUSION AND FUTURE WORKS

The gesture-controlled glove for quiet communication in military team communication offers a potent and cutting-edge solution to improve operational security and efficiency. This technology transforms how communication is done in special military operations and the protection of the troops. Soldiers must infiltrate hostile territory in small teams, such as four- or eight-man teams, for a variety of operations, including reconnaissance (LRRP; Long Range Reconnaissance Patrols), sniper operations, hostage rescue, and small team ambush missions and Fight in Build-up Areas (FIBUA) by allowing soldiers to convey orders and information through hand gestures by maintaining the silent communication (Fig. 9).



Fig 9: Wearable Handheld set

Verbal communication is frequently dangerous since it raises the possibility of being heard by the opponent. With the gesture-controlled glove, soldiers can effortlessly communicate crucial messages (predefined messages relevant to the operations) without saying a word, greatly lowering the chance that their locations will be compromised.

Additionally, this technology enhances military units' ability to communicate effectively. A consistent and simple means of communicating commands is offered by the glove, ensuring clear and succinct communication. It enables quick and accurate coordination, allowing team members' actions to be seamlessly synchronized. The creation and use of the gesture-controlled glove also advances knowledge and skills in wireless communication, sensor technologies, signal processing, and human-machine interaction. The project promotes investigation and invention, expanding knowledge and use in these areas.

The gesture-controlled glove can also be a powerful tool in challenging operational environments. It improves situational awareness, speeds up decision-making, and raises the success rates of missions as a whole. The glove gives military troops a tactical advantage by enabling more clandestine operations by minimizing the reliance on verbal communication. An important development in military technology is the gesture-controlled glove enabling silent communication in team communications. Military teams now function in a whole new method that improves their capabilities and ensures the safety and completion of crucial operations. This is made possible by its capacity to offer silent, effective, and secure communication.

Using an external antenna to the Bluetooth module the operational range of the device can be extended up to 100 meters in open terrain.

A gesture-controlled glove's capabilities can be increased and its ability to recognize gestures improved by adding more flex sensors. The glove can recognize a larger variety of hand movements and gestures if additional flex sensors are attached to various fingers, hands, or other portions of the body. A wider range of commands and activities are possible thanks to the finer control and more accurate gesture detection made possible by this. The glove becomes more versatile and adaptable to various user preferences and requirements by recording a wider range of hand movements. It enhances the gesture-controlled glove's overall functionality and user experience, making it a more effective instrument for precision control and silent communication in military team communication or other applications. We can assign more commands in response to more flex sensors being added.

#### REFERENCES

Telluri, P., Manam, S., Somarouthu, S., Oli, J.M. and Ramesh, C. (2020). Low cost flex powered gesture detection system and its applications. [online] IEEE Xplore. doi:<https://doi.org/10.1109/ICIRCA48905.2020.9182833>

Muthmainnah Mohd Noor, N., Azraei Azim Ng, A. and Rohidatun, M.W. (2022). Hand gesture-based flex sensor for PC games. [online] IEEE Xplore. doi:<https://doi.org/10.1049/icp.2022.2258>.

S, Nimi.W., P, M.J.E., R, J., S, R.I. and F, A.F. (2023). Human Posture Monitoring using Flex Sensor. [online] IEEE Xplore. doi:<https://doi.org/10.1109/ICCES57224.2023.10192780>.

[www.cryptomuseum.com](http://www.cryptomuseum.com). (n.d.). PRM-4515. [online] Available at:<https://www.cryptomuseum.com/crypto/racal/prm4515/index.htm> [Accessed 3 Jul. 2023].

[www.l3harris.com](http://www.l3harris.com). (n.d.). Falcon III® RF-7800V-HH Handheld VHF Tactical Radio | L3Harris® Fast. Forward. [online] Available at: <https://www.l3harris.com/all-capabilities/falcon-iii-rf-7800v-hh-handheld-vhf-tactical-radio> [Accessed 3 Jul. 2023].

[www.motorolasolutions.com](http://www.motorolasolutions.com). (n.d.). SRX 2200 Combat Radio - Enhanced - Motorola Solutions. [online] Available at: [https://www.motorolasolutions.com/en\\_us/products/two-way-radios/project-25-radios/portable-radios/srx2200.html#tabproductinfo](https://www.motorolasolutions.com/en_us/products/two-way-radios/project-25-radios/portable-radios/srx2200.html#tabproductinfo). [Accessed 3 Jul. 2023].

Wikipedia. (2022). Flex sensor. [online] Available at: [https://en.wikipedia.org/wiki/Flex\\_sensor](https://en.wikipedia.org/wiki/Flex_sensor). [Accessed 3 Jul. 2023].

Electronics, E., Electronics, P., Electronics, A., Things, I. of, Electronics, A., Vehicles, E., Events, Robotics, Circuits, 555, Projects, A., Projects, R.P., News, E., Forum, E. and Calculators (2020).

Arduino to Arduino Bluetooth Communication using Master Slave Configuration. [online] Circuit Digest. Available at: <https://circuitdigest.com/microcontroller-projects/arduino-to-arduino-bluetooth-communication-using-master-slave-configuration>. [Accessed 3 Jul. 2023].

#### ACKNOWLEDGMENT

I would like to express my sincere gratitude to all personnel who have contributed to the successful completion of this research project. And also, special thanks are given to my supervisor Major R.M.C.P. Ranasinghe and LCdr MRRA Bandara for his valuable guidance and expertise throughout this project. Furthermore, I would like to express my appreciation to General Sir John Kotelawala Defence University for imparting access for related resources as well as facilities. Finally, I am grateful to my friends and family members for their encouragement throughout the research process.

#### AUTHOR BIOGRAPHIES



KT Sehan is a 3<sup>rd</sup> year undergraduate of General Sir John Kotelawala Deference University, following the B.Sc. in Electronic & Telecommunication Engineering. The mentioned project was designed and implemented with my dedication and perseverance in order to keep a silent communication for a military team.



RMCP Ranasinghe is a graduate of General Sir John Kotelawala Deference University with B.Sc. in Electrical & Electronic Engineering. He is currently reading a MSc in Telecommunication at University of Moratuwa. Also, he is an Associate Member of the IESL.



MRRA Bandara is a graduate of General Sir John Kotelawala Deference University with B.Sc. in Electrical & Electronic Engineering. He is currently reading a MSc in Telecommunication at University of Moratuwa. Also, he is an Associate Member of the IESL.