

Design of a new aircraft wing inspired by the Magnificent Frigate bird

UI Weerathunga^{1#}, KKSP Upasena¹, J.I. Abeygoonewardena¹ & R.M.P.S. Bandara¹

¹Faculty of Engineering, General Sir John Kotelawala Defence University, Kandawala Road, Ratmalana 10390, Sri Lanka.

[#] Corresponding author; <ushalimalka@hotmail.com>

Abstract— *The aircraft wing design plays a compelling role on the overall aircraft performance. The contemporary society has come to integrate inspirations time-tested by nature, within the modern technological innovations. This paper fixates upon the field of biomimetics, experimenting on the wing planform of a Magnificent Frigate bird that can be embodied into a conceptual aircraft wing. This specific seabird was chosen as studies confirm that it has the lowest wing loading and drag coefficient among all birds. The conceptual wing this research is based upon was designed using SOLIDWORKS software, incorporating a NACA 2412 aerofoil in order to compare the end results with the wing of a conventional aircraft. Simulations were conducted for a range of angles of attack, at different Reynold's numbers using a computational simulation software, ANSYS® 18.1, to verify whether the design offers improved aerodynamic properties, for an aircraft wing. Two turbulence models were used, namely, Spalart-Allmaras and K-epsilon. The results obtained for both cases were compared, and it was seen that improved performance resulted when using the with K-epsilon turbulence model.*

Keywords— *Biomimetics, Computational Fluid Dynamics, Magnificent Frigate Bird, Wing Planform Design*

I. INTRODUCTION

Nature has inspired design and throughout human history. Aviation industry too has taken great leaps through observation of nature and applying it into the developing technology since the first flight by the Wright Brothers in 1903 (Benson, 2014). Engineers and scientists now look back to the nature's masters of flight in order to further optimize the aircraft of the future, for they have been time tested and evolved into perfection by nature. Designing of aircraft wings based on characteristics of the wings of birds can be traced back to the 14th century where the polymath of Italian renaissance, Leonardo Da Vinci's sketches of the "Flying Machine", for which he has directly focused on how the birds achieved flight using their wings (Moon, 2007). This research focuses on Magnificent Frigate Bird which are considered to be at the extremity of evolution (Joyce, 2016).

The Magnificent Frigate bird is an aggressive and powerful seabird, with a deserved reputation as the pirate of the high seas. It ekes out a tenuous existence from the

resource-poor surface of the tropical ocean (Sobczak, 2011). At present it has drawn the attention of designers and aviators due to its remarkably unique wing shape and distinctive aerodynamic properties. It possesses the lowest wing loading of all species of birds and low drag coefficient (Yi, et al., n.d.). This research focuses on how the design characteristics of the frigate bird's wing could be extracted and embedded into a conceptual aircraft wing design in order to obtain elevated aerodynamic properties and performance.

II. LITERATURE REVIEW

The Magnificent Frigate Bird, more scientifically known as *Frigata magnificens*, is considered to be at the extremity of evolution as it has to survive through the scarcity of food in Indian and Pacific Ocean regions which has led it to spend an utmost portion of its lifetime airborne over the ocean (Joyce, 2016). Taken that it's wings are not waterproof (Griggs, 2016), such adverse survival situations has led this bird to signify various aerodynamic demands such as extreme endurance and very high manoeuvrability. To serve this purpose, it has large wings with tapered wingtips and a widespread wingspan of 2 to 5 meters, generating a large amount of lift and also has a highest flying speed during predation, which goes up to 400 kilometres per hour (Pariona, 2019).

This bird has the lowest wing loading of all species of birds. Their wings also have the advantage of having a very low drag coefficient and an intermediate lift coefficient. The forward bend in the wingspan forms a 'S' shaped airflow over the wing which reduces the leading edge's pressure (Yi, et al., n.d.). They can fly in altitudes above 4000 m where even oxygen is somewhat scarce and fly through freezing temperatures in which no other bird could possibly survive in (Joyce, 2016).

The following factors had been identified as the most vital elements needed in the case of a bird's flight. They are; a high-strength, yet light-weight structure, wings that can generate lift and forward thrust and also feathers can smoothen the flow and flight controls with fast response. The feathers too play an important role as they have a very

unique structure which makes it extremely light yet structurally very strong and flexible. The author states that the strength to weight ratio of the feathers of a bird goes far beyond that of any man-made structure (Dhawan, n.d.).

Aljoscha N. Sander, who has conducted a research based on the wing shape of the Frigate bird claims that this specific wing planform generates low wing loading and a high aerodynamic efficiency (lift to drag ratio). Thereby he suggests this wing planform as an excellent candidate for unmanned aerial vehicles for both civilian and military purposes (Sander, 2017). Another research done upon the subject discloses that the forward bending wingspan (as of the frigate bird's) can improve the stall characteristics resulting in lower stall speed. Furthermore, they have declared that the drag of their wing design decreased in the forward bent wingspan, compared to the conventional wing. Yet they have also concluded that the specific design that they have considered generates a lift and an aerodynamic efficiency inferior to that generated by the conventional wing, at low angles of attack (Akos, et al., n.d.).

In an article where CFD simulations had been used to determine the outcomes due to porosity of a 2D flat plate, it has been observed that passive flow suction due to porosity caused a decrease in the drag and also the lift generated. This research confirms that the porosity has a considerable effect on aerodynamic performances when the appropriate permeability is reached (Bae, et al., 2012).

A research focused on various observations done on birds states the application of principles of incompressible aerodynamics to the flapping and gliding flight of birds, highlighting the bird wing as a flexible yet very complex aerofoil which consists of features such as adjustability for control and a cambered nature (Dhawan, n.d.).

Wing loading can be defined as the ratio of the gross weight to the planform area of the lifting surface of a wing. Lower wing loading decreases the landing and take-off distance, enables the aircraft to have a better climb rate at lower Mach numbers to the same power requirement, allows the aircraft to have a lower stalling speed which assists very much during take-off and landing, permits greater manoeuvrability in flight and also increases flight ceiling and facilitates it with a higher glide distance (Corke, n.d.). The wing design impacts upon a flying bird's critical factors, stability and manoeuvring and other flight performances (Tobalske, 2007). Power requirement in the case of flight has proved to be much greater to all other methods of locomotion of animals (Schmidt-Nielsen, 1972).

III. METHODOLOGY

A conceptual wing model which incorporating the wing planform of the frigate bird was designed using SOLIDWORKS 2017 software. This was used as a reference subject. The required planform shape was extracted from a portrait of Magnificent Frigate Bird (Figure 1).



Figure 1. Wing planform of Magnificent Frigate Bird

Two solid wing models were generated; the Frigate wing (Figure 2) and a conventional wing (Figure 3) which incorporates a NACA 2412 aerofoil. The conventional wing model was generated to use as the reference to facilitate comparison between the two wing models.

When designing the solid model of the conventional wing

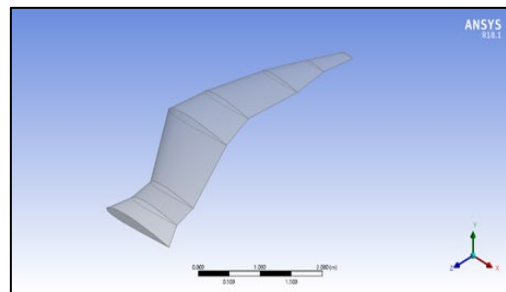

Figure 2. Isometric view of Frigate wing

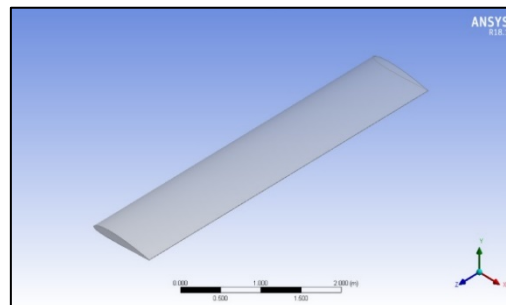

Figure 3. Isometric view of NACA 2412 wing

model, the aerofoil was first scaled to match the chord length of 0.972m and then extruded to a length 4.9 m. For the conceptual solid wing model, the NACA 2412 aerofoil shape corresponding to the different sections at the wing was scaled accordingly. Then they were connected to complete the solid wing model. The conceptual wing was designed such that the same aerofoil (NACA 2412) is continued throughout the whole wingspan. Both wings were designed to have a similar wingspan as well as similar surface area. This will allow to run simulations on both wings under similar conditions.

Both wing models were loaded through ANSYS® 18.1 and domains were created over them with the dimensions shown in Table 1.

Table 1: Dimensions of the domain

Direction	Length, m
+X	12
+Y	5.5
+Z	6
-X	3.5
-Y	5.5
-Z	6

The wing model was rotated about the Z axis to conduct simulations for different Angles of Attack (AoA). The simulations were performed under similar conditions.

The domains as well as the surface of the wing models were meshed. For both wing models, both 'Body Sizing' as well as 'Face Sizing' functions were used. While the 'Body Sizing' function meshes the domain, the 'Face Sizing' function meshes the surface of the wing. The 'Inflation' function was also used to create ten inflation layers around the wing models. For both wing models, the number of elements were kept in the region of 3.4 to 4 million. The lack of computational power to run the simulations properly on a finer mesh led to this limitation.

Simulations were run on ANSYS® 18.1 under two different turbulence models; Spalart-Allmaras and K-Epsilon, for both wing models. Simulations were also run under three different Reynold's numbers to observe the variations of C_l , C_d and C_l/C_d in different velocity conditions. The velocities the simulations were run in are 0.18 M (62.6 ms^{-1}), 0.4 M (137.2 ms^{-1}) and 0.6 M (205.8 ms^{-1}). As air flows under 0.3 M are considered as incompressible flows, the simulations at 0.18 M were carried out using a Pressure based solver.

Since the flow conditions simulated in this research were subsonic, and did not render ant shock profiles, it was reasonable to use the Pressure based solver rather than a Density based solver.

IV. RESULTS AND DISCUSSION

Results and Discussion presents a complete analysis of the comparisons done between the results obtained from the simulations done to the conventional wing and the Frigate wing. For this analysis, the graphs were plotted using Microsoft Excel 2016 Software, considering the AoA vs aerodynamic properties such as C_l , C_d and C_l/C_d were used.

A. Coefficient of Drag variation with AoA

The values obtained for C_D at 0.18 M, 0.4 M and 0.6 M, from -4° to 10° AoA, when simulations were done using K-epsilon turbulence model can be depicted by the Figure 4, Figure 5 and Figure 6.

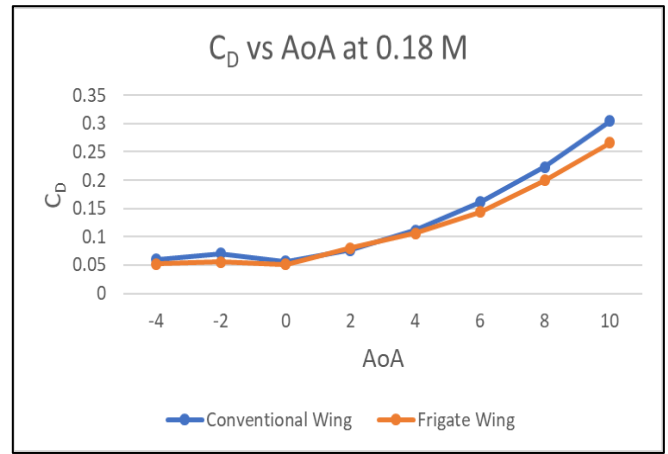

Figure 4: Coefficient of Drag vs AoA graph at 0.18 M

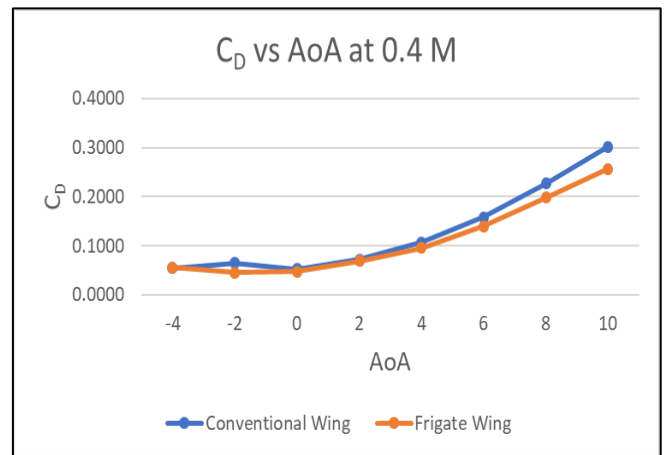

Figure 5: Coefficient of Drag vs AoA graph at 0.4 M

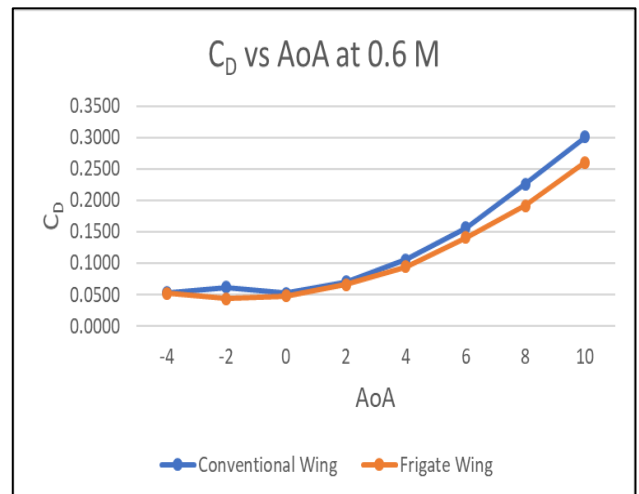

Figure 6: Coefficients of Drag vs AoA graph at 0.6 M

Throughout the graphs of C_D vs AoA at 0.18 M (Figure 4), 0.4 M (Figure 5) and 0.6 M (Figure 6), the Frigate wing portrays better performance than the conventional wing by an average of 10%, 11.67% and 11.63% respectively.

The Frigate wing showcases a slightly tapered wing planform which may have affected the above results. A tapered wing consists of smaller wing tips, which contributes to reducing the size of the wing tip vortices

which in turn reduces induced drag experienced by the aircraft.

When simulations were run using the Spalart-Allmaras turbulence model, the results obtained were contradictory. For an example, the C_D values of the Frigate wing at 0.4 M, exceeded those of the conventional wing as depicted by the graph below (Figure 7).

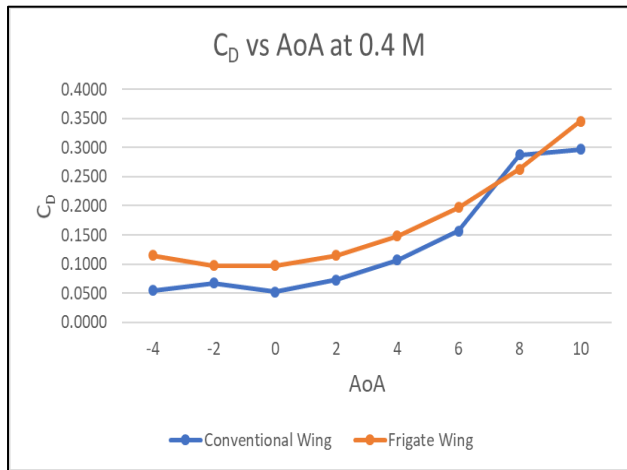

Figure 7: Coefficient of Drag vs AoA at 0.4 M using Spalart-Allmaras

Furthermore, it was observed in simulations run using K-epsilon turbulence model, that as the Mach number (M) increases, the C_D of the Frigate Wing decreases (Figure 8).

B. Coefficient of Lift variation with AoA

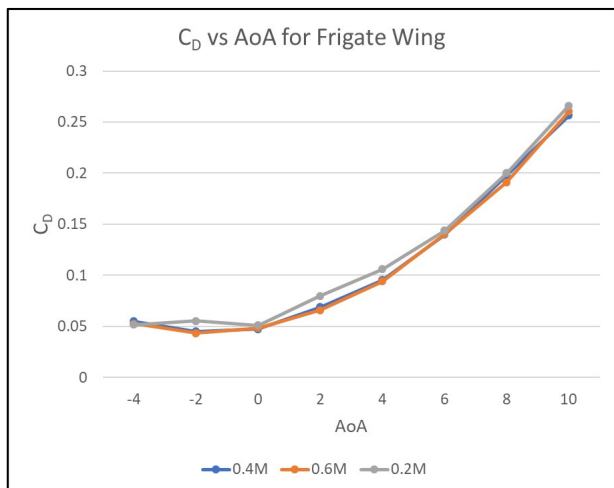

Figure 8: Variation of C_D in Frigate Wing with Mach number

Even though the coefficient of drag results of the Frigate wing were favourable for all considered Mach numbers, coefficient of lift results of it were less satisfactory in comparison to the conventional wing. It can be clearly seen by the graph (Figure 9) of Coefficient lift vs AoA at 0.4 M below.

C. Coefficient of Lift/Coefficient of Drag variation with AoA

It was observed, throughout the results obtained that the aerodynamic efficiency (C_L/C_D) between the Frigate wing

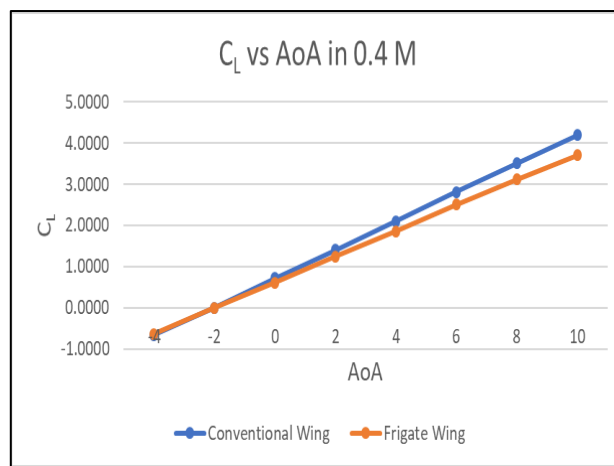

Figure 9: Coefficient of Lift vs AoA at 0.4 M

and the conventional wing are very similar for all considered Mach numbers. Such results obtained from simulations run using K-epsilon turbulence model at 0.4 M are as follows (Figure 10).

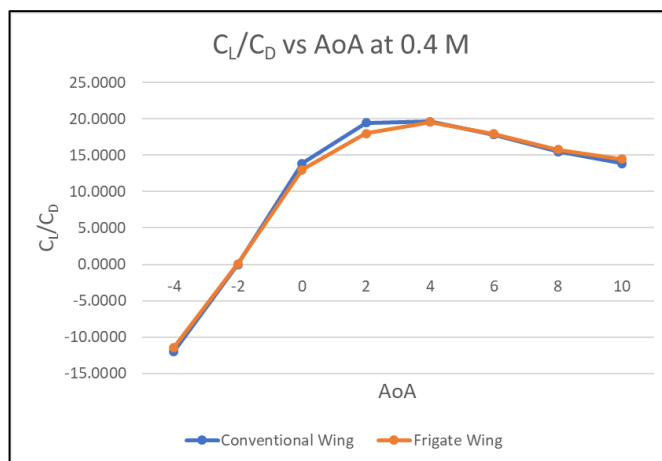

Figure 10: Aerodynamic efficiency vs AoA at 0.4 M

V. CONCLUSION

Observing the results obtained by running simulations on the two wing designs using Spalart-Allmaras turbulence model and K-epsilon turbulence model, a significant deviation was seen only in the case of results obtained for the drag coefficient of the Frigate wing.

When considering the outcomes of aerodynamic properties such as coefficient of drag, coefficient of lift and aerodynamic efficiency, the Spalart-Allmaras model gave results which depicted less performance by the Frigate wing, relative to the conventional wing. Whereas in the case of the results obtained by running simulations using K-epsilon turbulence model, it depicted that the Frigate wing possessed less coefficients of drag comparative to the conventional wing, in all Reynold's numbers considered. The Frigate wing possessed about 10%, 11.67% and 11.63% of lesser coefficient of drag at 0.18 M, 0.4 M and 0.6 M respectively, comparative to the conventional wing. This is because of the Frigate wing's smaller tip of the tapered wing shape. It creates smaller wing tip vortices compared to the conventional wing model resulting in lower induced drag.

The reason for the overall deviation in the results obtained by the two turbulence models could have been because the Spalart-Allmaras turbulence model considers parameters such as pressure, viscosity closer to the boundary of the wing whereas K-epsilon turbulence model predicts the same parameters from an area far from the boundaries where free stream exists, when solving equations.

Nevertheless, it can be concluded that the deviation of the results of aerodynamic performance from the expected is due to:

- The porosity in a bird's wing due to its feathers:

As Bae mentions in his research, the porosity of a bird's wing has a significant effect on its flight due to passive flow suction. The fact that this cannot be implemented in an aircraft wing in an effective manner can lead to deterioration of aerodynamic performance of an actual aircraft wing.

- The ability of a bird to flap its wings and the inability of an aircraft to do so.
- The ability of a bird to change its wing shape amid flight and the inability of a conventional aircraft wing to do so:

As Dhawan elaborates in his research, bird's wing goes through bending and twisting motions to not produce unnecessary resistance to the flight which increase drag. Even though modern aircraft wings have the ability to sweep back their wings to decrease drag when travelling at high speeds, they are still unable to perform bending and twisting motions to that extent of a bird.

Published papers confirm that the more suitable turbulence model for simulation of flows upon aerofoils and complex geometries is the K-epsilon realizable model. This is because of the delay in flow separation that occurs when using this model which in turn assists simulations to run in a much smoother flow. Thereby, giving more weight to the results obtained by the K-epsilon turbulence model simulations, it can be concluded that the conceptual wing design based upon the Magnificent Frigate bird is quite favourable for reducing the coefficient of drag generated during flight.

References

Akos, Z., Nagy, N., Severin, L. & Vicsek, T., n.d. Thermal Soaring flight of birds and UAVs.

Autodesk Inc, n.d. *Compressible Flows*. [Online] Available at: <https://help.autodesk.com/cloudhelp/2014/ITA/SimCFD/files/GUID-620F44CE-9506-4C48-9E9C-6C689345B008.htm>

Bae, Y., Jeong, Y. & Moon, Y., 2012. Computation of flow past a flat plate with porous trailing edge using a penalization method. *Computer Fluid*, Volume 66, pp. 39-51.

Benson, T., 2014. *National Aeronautics and Space Administration*. [Online]

Available at: <https://wright.nasa.gov/overview.htm> [Accessed 2 September 2018].

Corke, T. C., n.d. *Design of Aircraft*. New Jersey: Pearson Education, Inc..

Dhawan, S., n.d. Bird Flight.

Griggs, M. B., 2016. *POPULAR SCIENCE*. [Online] Available at: <https://www.popsoci.com/how-frigate-birds-stay-in-air-for-months-at-time> [Accessed 3 September 2018].

Joyce, C., 2016. *Nonstop Flight : How the frigatebird can soar for weeks without stopping*. [Online] [Accessed 7 September 2018].

Moon, F. C., 2007. *The Machines of Leonardo Da Vinci and Franz Reuleaux: Kinematics of Machines from the Renaissance to the 20th century*. Dordrecht: Springer.

Pariona, A., 2019. *The fastest birds in the world*. [Online] Available at: www.worldatlas.com/articles/the-fastest-birds-in-the-world

Sander, A. N., 2017. Biometric wing-design, inspired by the magnificent frigate bird *Fregata magnificens*. *Journal of Experimental Biology*.

Schmidt-Nielsen, K., 1972. *Locomotion : Energy cost of swimming, running and flying*. s.l.:s.n.

Sobczak, C., 2011. *The Living Gulf Coast: A Nature Guide to Southwest Florida*. s.l.:Indigo Press L.L.C..

Tobalske, B. W., 2007. *Biomechics of Bird Flight*. [Online] Available at: <https://www.ncbi.nlm.nih.gov/pubmed/17766290>

Yi, M., Yu-rong, L., Jing-fu, J. & Qian, G., n.d. Analysis of the Aerodynamic characters of Bionic Wingspan on the Basis of Frigate WWing Structure.

ACKNOWLEDGEMENT

This research was supported continuously by the Department of Aeronautical Engineering of General Sir John Kotelawala Defence University. Initially we would like to pay our colossal gratitude to Mrs. J.I. Abeygoonewardena, who was the supervisor of our project, guiding us throughout with the expertise and insight of the subject and for all the advices and project progress upkeep.

Also our sincere appreciation goes to Dr. RMPS Bandara from the Department of Mechanical Engineering and Mr. SLMD Rangajeewa from the Department of Aeronautical Engineering, for the patient guidance and endless support throughout the project and for all the knowledge shared with us regarding computational fluid dynamic software, which was much needed for carrying out this project successfully.

Moreover, our heartfelt gratitude is offered to Mr. DD Karunaratne, a graduate from the Department of

Mechanical Engineering of KDU, for his immense support to us in designing the wing using solid modelling software.